

An improved technique and its implementation for control of high power heaters in large autoclaves and similar plants

G.M.Kamalakaran^a and Amit Kumar Gupta^a.

^aAdvanced Composites Division, National Aerospace Laboratories, Bangalore – 560 017, India.

*e-mail: kannangm@nal.res.in

Abstract: This paper presents an improved technique and its implementation for control of high power heaters in large autoclaves and similar plants. These plants are equipped with electrical heaters, which are grouped into number of banks to reduce the quantum of load/power change and improve operability, controllability and reliability. Conventionally, each heater bank is controlled through a power controller (usually Silicon Controlled Rectifier based). The total number of power controllers employed in a system will be equal to the total number of heater banks and they all share a common control signal provided by the temperature controller. While this is an obvious method, it is very expensive and results in decreased power factor and increased harmonic distortions. To overcome the above limitations, this paper explains a better technique; namely, '**Heater Power Steering Logic (HPSL)**' and its implementation using Analog circuit and also using Programmable Logic Controller.

Key words: Industrial Automation and Process Control; autoclave, PLC, heater power control

INTRODUCTION

Electrical heating is very common in process industries as it is clean and easy to control. Many plants such as large autoclaves (used for fabrication of aircraft structures) and electrical ovens have high power heaters of several hundreds of Kilo Watts. Heaters are grouped in to number of banks to enable ease of operation and control, improve reliability, minimize the effect of failure of few heaters or SCR (Silicon Controlled Rectifier) controllers on the whole of heating process, reduce the quantum of power drawn or switched from the power source (in case of integral cycle control) etc. Generally each heater bank is controlled through an independent SCR controller, thus making the number of SCR controllers equal the number of heater banks. Control signal generated by the temperature controller is fed to every SCR controller. While this method is simple to implement, it entails couple of disadvantages. Each heater bank needs a SCR controller, which is expensive and the control signal has to be routed to all the SCR controllers with due consideration of interferences and electrical isolation issues. Further, Phase angle controlled SCR controller introduces harmonic distortion and reduces power factor while the

Zero-Cross over or integral-cycle-control based SCR controller presents a continuously varying power demands (Full power or zero power) to the source which becomes unacceptable when the power switched is comparable to the source power. **Fig.1, illustrates the conventional heater power control method.**

This paper explains a technique namely, '**Heater Power Steering Logic (HPSL)**' to overcome the above-mentioned disadvantages. In autoclave and oven the total heater capacity is based on the maximum temperature to be reached at the peak rate of heating with the maximum design charge (weight and specific heat of all the materials loaded) and the weight and specific heat of the shell, thermal insulation and other internal items. As a result, in majority of the cases, the heat input required to maintain the temperature is much lesser than the total heater capacity. HPSL takes advantage of this fact and achieves the required control functionality by using SCR controller for one heater bank (typically about 20% of the total heater power) and contactors for the rest.

Two ways of implementing HPSL are 1) Through a Stand-alone electronic card and 2) Through a Programmable Logic Controller (PLC). Both these techniques have been successfully implemented in number of autoclaves designed by NAL and are functioning very well since many years.

PRINCIPLE

The HPSL converts the heat-demand control signal (provided by the temperature controller) into discrete steps of heater power demand that can be met by the contactor controlled heater banks and a linear quantity of power demand that can be met by the SCR controlled heater bank. **Fig.2 illustrates the HPSL based heater power control method.** The function of HPSL is shown in the table-1 for a case of five heater banks each catering to 20% of total heater capacity and one of them with SCR control. For example, if the control signal is 30%, the Heater Bank – 1(HB1) will be ON and the SCR controlled bank will provide 50% of power.

Heat demand Signal in (%)	HB1 (on / off)	HB2 (on / off)	HB3 (on / off)	HB4 (on / off)	SCR Signal in (%)
0 to 20	Off	Off	Off	Off	0 to 100
21 to 40	On	Off	Off	Off	0 to 100
41 to 60	On	On	Off	Off	0 to 100
61 to 80	On	On	On	Off	0 to 100
81 to 100	On	On	On	On	0 to 100

Table 1: Heater bank status as function of control signal (Heater hysteresis is not shown for simplicity)

HPSL IMPLEMENTATION THROUGH ANALOG CIRCUIT:

The HPSL was implemented using Operational amplifiers, comparators and transistors. The card was named as Power Steering Circuit (PSC). Figure-3 shows the circuit schematic of PSC. Salient features of the PSC includes, simplicity, economy, voltage or current input with offset and gain adjustment, discrete output for four heater contactors, linear output for the SCR controller, hysteresis for heater relays, DIP

switches to bypass the circuit and directly switch the heater relay, ON indication, adjustment facility for SCR output etc. The first stage of the PSC is basically a current to voltage converter. The heat demand signal is a current signal in the range of 4-20mA. This signal is converted to voltage and fed to the four parallel comparators and also to the SCR signal stage. The other input to the comparator is the pre-set reference voltage. The comparators output as a function of heat demand signal would correspond to table-1. The final stage of the PSC is a summer configuration, whose output voltage depends on the heat demand signal, the number of heater banks in ON state and also the gain of the op-amp, which is five. Thus, if the heat demand signal varies from 0 to 2V the SCR signal would vary from 0 to 10V. If the heat demand signal exceeds 2V, say 3V, then the comparator on the lowest rung would turn ON. This would generate about 2V at the ‘summer’ stage and the net input to this stage would become 1V. Hence, the SCR control signal would become 5V, which is the desired operation. The resistors R-23 to R-26 provides hysteresis for heater relay operation. The LED indicate the heater relay status. The PSC operates the heater relay, which in turn operates the heater power contactor through other interlocks. A bypass switch is provided across all the transistor output stages to forcefully switch ON the heater bank.

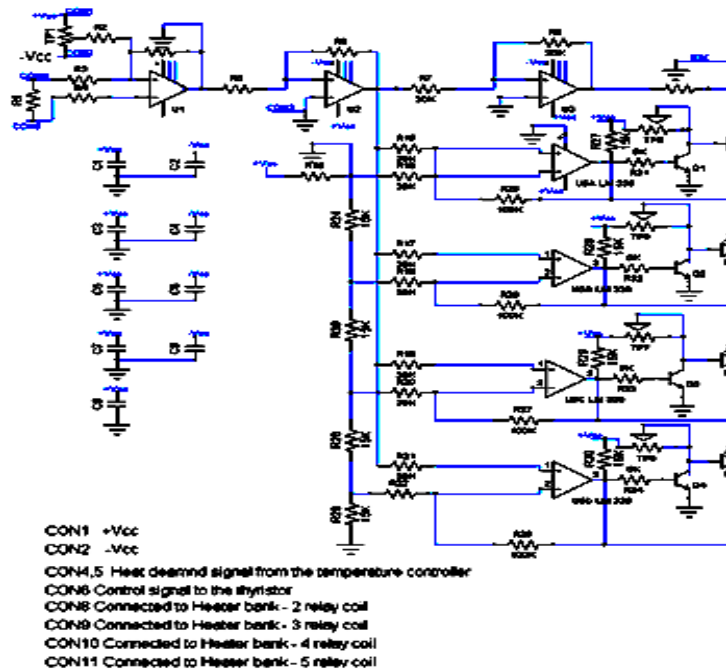

fully thyristor controlled autoclave both during ramp-up and soak (constant temperature) period. It has improved the power factor to nearly unity for heating loads exceeding 20% and reduced the harmonics generation considerably. Cost of installation of heater power control system was brought down by about 70%.

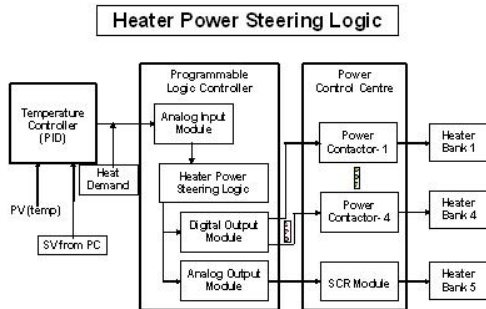

Fig. 2 Heater Power Steering Logic

HPSL IMPLEMENTATION THROUGH Programmable Logic Controller (PLC):

To implement HPSL, PLC should have means to accept the heat demand signal (analog), produce SCR control signal (analog) and also produce digital outputs (On/Off) to the power contactors. The analog signal transfer to and from PLC can be carried out either through PC-PLC communication link or through analog input/output module of the PLC. The later method was chosen to ensure HPSL operation even if the PC fails. The logic implemented in the PLC is fairly simple. The control signal is digitized and treated as a number having a range of 0 to 1000 in proportion to the heat demand signal. Hysteris is realized by two ways; 1. Presence of heater On or Off signal continuously for a preset time interval. 2. Appropriate difference in the control signal value for turning the heater On or Off. The heater contactors were operated on the First In First Out basis (FIFO) as against sequential operation, in order to use the heaters uniformly.

Figure 4 shows the thyristor bank for heater power control. Figure 5 a and b shows the autoclave control and power panels respectively.

RESULTS

The HPSL provided the same temperature control accuracy (within +/- 1°C) as that of the



*Fig. 4 Thyristor Bank
For Heater power Control*



Fig. 5.a Autoclave control panel



Fig. 5.b Autoclave power panel

CONCLUSIONS

The HPSL brings down installation cost and improves overall performance and reliability without affecting the control accuracy. It has improved the power factor significantly and reduced the generation of harmonics as eighty percent of the heaters are operated through contactors and only twenty percent of the heaters are operated through SCR. HPSL is

particularly suitable for autoclaves, ovens and similar plants where the variations in heat demand are less as compared to the installed heater capacity. Both the linear IC based card and the PLC based method have been successfully implemented and are functioning well in the autoclaves designed by NAL.

ACKNOWLEDGEMENTS

Author is very thankful to The director – NAL, Mr. M. Subba Rao, former head , ACD – NAL and Mr. H.N. Sudheendra , head, ACD, Mr. G.N. Dayananda, deputy head, ACD and Mr. J. Ramaswamy Setty for their support and encouragement. Also he is thankful to Mr. Upender.A, former STA, ACD and autoclave electronics team members for their support.

REFERENCES

1. G.M. Kamalakannan and M. Subba Rao , “Development of computer based process control system for an autoclave to cure polymer matrix composites”, *International conference on Instrumentation – 2004*, Pune.
2. G.M. Kamalakannan, “ Ethernet based online process monitoring and controlling of a plant having RS- 232 or RS- 485 equipment”, *National symposium on Instrumentation – 2007*, Tiruchengode.
3. <http://www.hdrpower.com/literature.asp>
4. <http://www.caloritech.com/>

The equation for the heater bank output signal can be given as; Heater bank 1 signal = (Heat demand – 2 X number of banks ON) X Gain

A block diagram illustrating the implementation of HPSL using PLC is given below. Heat demand in steps of 20% were met by heater bank numbers one to four and balance heat demand that varies from zero to twenty percent was met through the SCR controlled bank.